

Moxa EtherDevice™ Switch

**EDS-P506A-4PoE Series
Hardware Installation Guide**

First Edition, July 2010



© 2010 Moxa Inc. All rights reserved.
Reproduction without permission is prohibited.

P/N: 1802005060010

Overview

The Moxa EtherDevice™ EDS-P506A-4PoE Series Ethernet switches are managed redundant Ethernet switches that come standard with 4 10/100BaseT(X) 802.3at/af (PoE/PoE+) compliant Ethernet ports, and 1 or 2 10/100BaseT(X) Ethernet ports or 1 or 2 100BaseFX (SC/ST-type connector) fiber ports. The EDS-P506A-4PoE Ethernet switches provide up to 30 watts of power per PoE port, and allow power to be supplied to connected devices (such as surveillance cameras, wireless access points, and IP phones) when power is not readily available or cost-prohibitive to provide locally. The EDS-P506A-4PoE Ethernet switches are highly versatile, and their fiber ports can transmit data up to 40 km from the device to the control center with high EMI immunity. The Ethernet switches support a variety of management functions, including Turbo Chain, IEEE 1588 PTP, Turbo Ring, RSTP/STP, IGMP, VLAN, QoS, RMON, bandwidth management, and port mirroring. The EDS-P506A-4PoE series is designed especially for security automation applications such as IP surveillance and gate of entry systems, which can benefit from a scalable backbone construction and Power-over-Ethernet support.

The EDS-P506A-4PoE can operate from 0 to 60°C or -40 to 75°C for T models and are designed to withstand a high degree of vibration and shock. The rugged hardware design makes the EDS-P506A-4PoE Series perfect for ensuring that your Ethernet equipment can operate in critical industrial environments, and complies with FCC and CE standards.

NOTE Throughout this Hardware Installation Guide, we use EDS as an abbreviation for Moxa EtherDevice Switch.

EDS = Moxa EtherDevice Switch

Package Checklist

The EDS-P506A-4PoE is shipped with the following items. If any of these items are missing or damaged, please contact your customer service representative for assistance.

- 1 EDS-P506A-4PoE EtherDevice Switch
- Hardware Installation Guide (this guide)
- CD-ROM with user's manual and Windows utility
- Moxa product warranty statement
- RJ45 to DB9 console port cable
- Protective caps for unused ports
- DIN-Rail mounting kit (attached to the EDS-P506A-4PoE's rear panel by default)

EDS-P506A-4PoE Panel Views (standard type)

EDS-P506-4PoE
Front Panel View

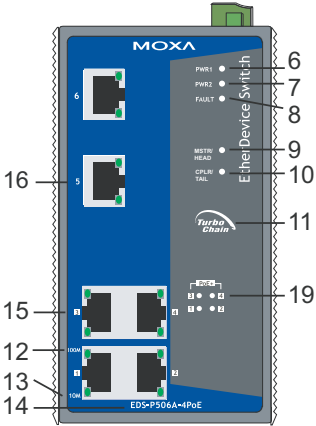

1. Grounding screw
2. Terminal block for power input PWR1/PWR2 and relay output
3. Heat dissipation orifices
4. Console port
5. DIP switches
6. Power input PWR1 LED
7. Power input PWR2 LED
8. Fault LED
9. MSTR/HEAD LED indicator
10. CPLR/TAIL LED indicator
11. Turbo Chain logo
12. TP port's 100 Mbps LED
13. TP port's 10 Mbps LED
14. Model Name
15. 10/100 BaseT(X) PoE Ports
16. 10/100 BaseT(X) Ports
17. Screw hole for wall mounting kit
18. DIN-Rail kit
19. PoE LEDs

Top Panel View

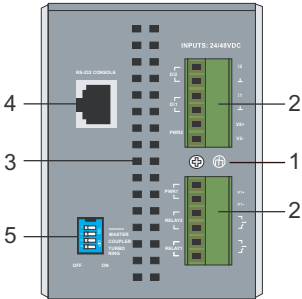

Rear Panel View

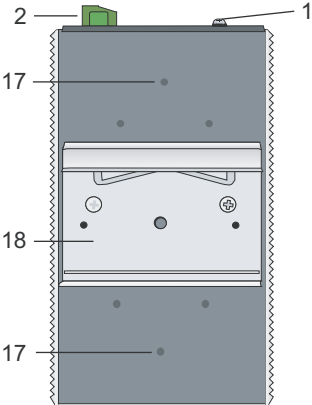

EDS-P506A-4PoE Panel Views (SC-type)

EDS-P506A-4PoE-MM-SC/
EDS-P506A-4PoE-SS-SC
Front Panel View

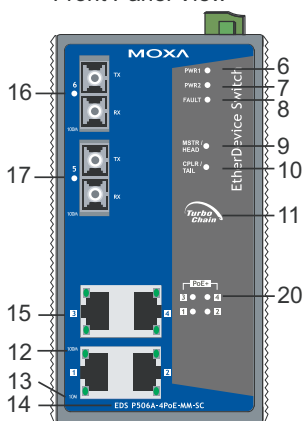

1. Grounding screw
2. Terminal block for power input PWR1/PWR2 and relay output
3. Heat dissipation orifices
4. Console port
5. DIP switches
6. Power input PWR1 LED
7. Power input PWR2 LED
8. Fault LED
9. MSTR/HEAD LED indicator
10. CPLR/TAIL LED indicator
11. Turbo Chain logo
12. TP port's 100 Mbps LED
13. TP port's 10 Mbps LED
14. Model Name
15. 10/100 BaseT(X) PoE Ports
16. 100BaseFX ports
17. FX port's 100 Mbps LEDs
18. Screw hole for wall mounting kit
19. DIN-Rail kit
20. PoE LEDs

Top Panel View

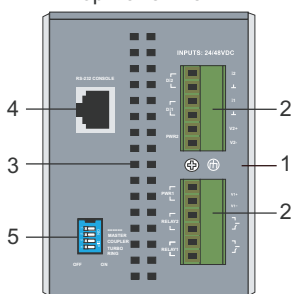

Rear Panel View

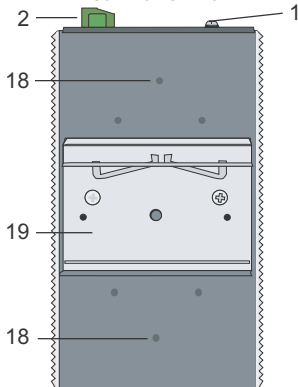

EDS-P506A-4PoE Panel Views (ST-type)

EDS-P506A-4PoE-MM-ST

Front Panel View

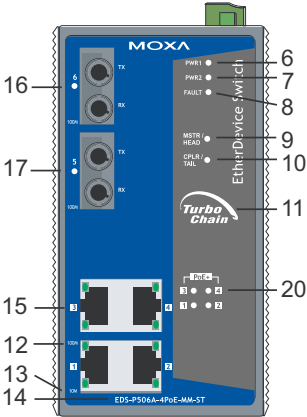

1. Grounding screw
2. Terminal block for power input PWR1/PWR2 and relay output
3. Heat dissipation orifices
4. Console port
5. DIP switches
6. Power input PWR1 LED
7. Power input PWR2 LED
8. Fault LED
9. MSTR/HEAD LED indicator
10. CPLR/TAIL LED indicator
11. Turbo Chain logo
12. TP port's 100 Mbps LED
13. TP port's 10 Mbps LED
14. Model Name
15. 10/100 BaseT(X) PoE Ports
16. 100BaseFX ports
17. FX port's 100 Mbps LEDs
18. Screw hole for wall mounting kit
19. DIN-Rail kit
20. PoE LEDs

Top Panel View

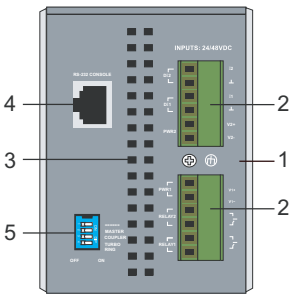

Rear Panel View

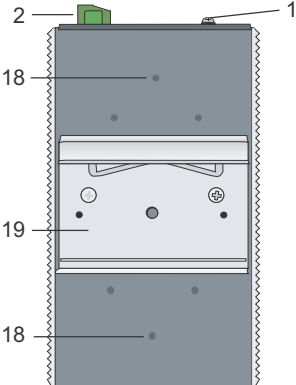

Mounting Dimensions

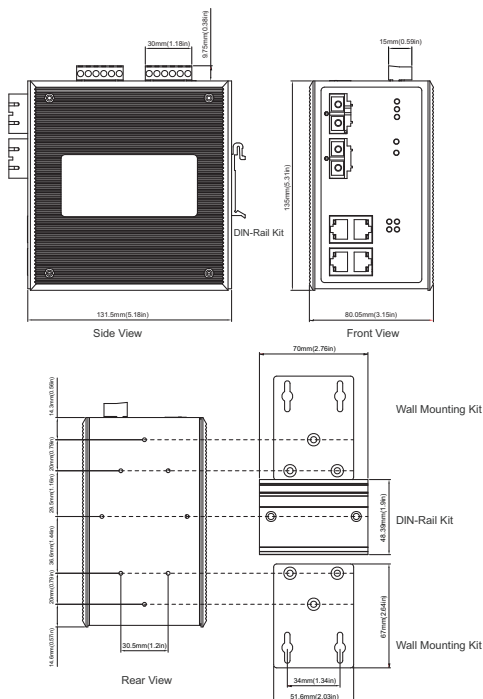

DIN-Rail Mounting

The aluminum DIN-Rail attachment plate should already be fixed to the back panel of the EDS-P506A-4PoE when you take it out of the box. If you need to reattach the DIN-Rail attachment plate to the EDS-P506A-4PoE, make sure the stiff metal spring is situated towards the top, as shown by the following figures.

STEP 1—Insert the top of the DIN-Rail into the slot just below the stiff metal spring.

STEP 2—The DIN-Rail attachment unit will snap into place as shown in the following illustration.

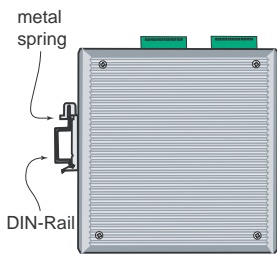
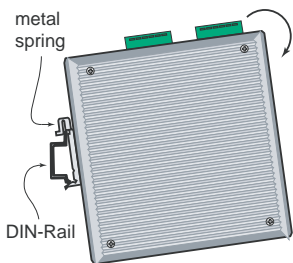

To remove the EDS-P506A-4PoE from the DIN-Rail, simply reverse Steps 1 and 2 above.

Wall Mounting (Optional)

For some applications, you will find it convenient to mount the Moxa EDS-P506A-4PoE on the wall, as shown in the following illustrations:

STEP 1—Remove the aluminum DIN-Rail attachment plate from the rear panel of the EDS-P506A-4PoE, and then attach the wall mount plates with M3 screws, as shown in the figure to the right.

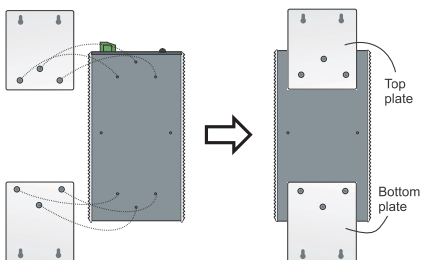

STEP 2—Mounting the EDS-P506A-4PoE on the wall requires 4 screws. Use the EDS-P506A-4PoE, with wall mount plates attached, as a guide to mark the correct locations of the 6 screws. The heads of the screws should be less than 6.0 mm in diameter, and the shafts should be less than 3.5 mm in diameter, as shown in the figure to the right.

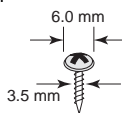

NOTE Before tightening the screws into the wall, make sure the screw head and shank size are suitable by inserting the screw through one of the keyhole-shaped apertures of the Wall Mounting Plates.

Do not screw the screws in all the way—leave about 2 mm to allow room for sliding the wall mount panel between the wall and the screws.

STEP 3—Once the screws are fixed to the wall, insert the four screw heads through the wide parts of the keyhole-shaped apertures, and then slide the EDS-P506A-4PoE downwards, as indicated in the figure at the right. Tighten the four screws for more stability.

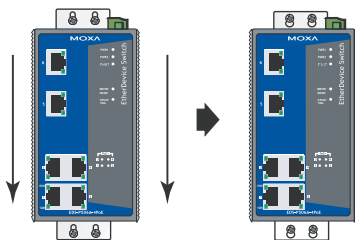

Wiring Requirements



WARNING

Do not disconnect modules or wires unless power has been switched off or the area is known to be non-hazardous. The devices may only be connected to the supply voltage shown on the type plate. The devices are designed for operation with a Safety Extra-Low Voltage. Thus, they may only be connected to the supply voltage connections and to the signal contact with the Safety Extra-Low Voltages (SELV) in compliance with IEC60950-1/EN60950-1.



ATTENTION

This unit is a built-in type. When the unit is installed in another piece of equipment, the equipment enclosing the unit must comply with fire enclosure regulation IEC60950-1/EN60950-1 (or similar regulation).



ATTENTION

Safety First!

Be sure to disconnect the power cord before installing and/or wiring your Moxa EtherDevice Switch.

Calculate the maximum possible current in each power wire and common wire. Observe all electrical codes dictating the maximum current allowable for each wire size.

If the current goes above the maximum ratings, the wiring could overheat, causing serious damage to your equipment.

Read and follow these guidelines:

- Use separate paths to route wiring for power and devices. If power wiring and device wiring paths must cross, make sure the wires are perpendicular at the intersection point.

NOTE: Do not run signal or communications wiring and power wiring through the same wire conduit. To avoid interference, wires with different signal characteristics should be routed separately.

- You can use the type of signal transmitted through a wire to determine which wires should be kept separate. The rule of thumb is that wiring that shares similar electrical characteristics can be bundled together.
- You should separate input wiring from output wiring.
- We advise that you label the wiring to all devices in the system.

Grounding the Moxa EDS-P506A-4PoE

Grounding and wire routing help limit the effects of noise due to electromagnetic interference (EMI). Run the ground connection from the ground screw to the grounding surface prior to connecting devices.



ATTENTION

This product is intended to be mounted to a well-grounded mounting surface such as a metal panel.

Wiring the Relay Contact

The EDS-P506A-4PoE has two sets of relay outputs—relay 1 and relay 2. Each relay contact uses two contacts of the terminal block on the EDS-P506A-4PoE's top panel. Refer to the next section for detailed instructions on how to connect the wires to the terminal block connector, and how to attach the terminal block connector to the terminal block receptor.

In this section, we illustrate the meaning of the two contacts used to connect the relay contact.

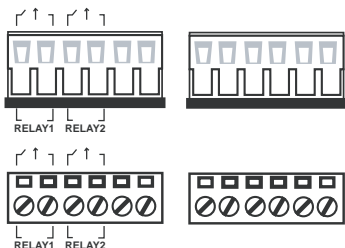

FAULT:

The two sets of relay contacts of the 6-pin terminal block connector are used to detect user-configured events. The two wires attached to the fault contacts form an open circuit when a user-configured event is triggered. If a user-configured event does not occur, the fault circuit remains closed.

Wiring the Redundant Power Inputs

The EDS-P506A-4PoE has two sets of power inputs—power input 1 and power input 2. The top two contacts and the bottom two contacts of the 6-pin terminal block connector on the EDS-P506A-4PoE's top panel are used for the two digital inputs. The top and front views of one of the terminal block connectors are shown here.

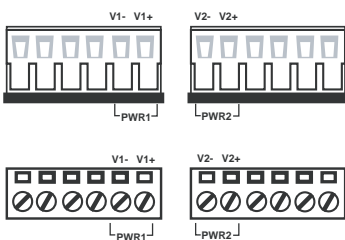

STEP 1:

Insert the negative/positive DC wires into the V-/V+ terminals, respectively.

STEP 2: To keep the DC wires from pulling loose, use a small flat-blade screwdriver to tighten the wire-clamp screws on the front of the terminal block connector.

STEP 3: Insert the plastic terminal block connector prongs into the terminal block receptor, which is located on the EDS-P506A-4PoE's top panel.

Wiring the Digital Inputs

The EDS-P506A-4PoE has two sets of digital inputs, DI 1 and DI 2. Each DI consists of two contacts of the 6-pin terminal block connector on the EDS-P506A-4PoE's top panel, which are used for the two DC inputs. The top and front views of one of the terminal block connectors are shown here.

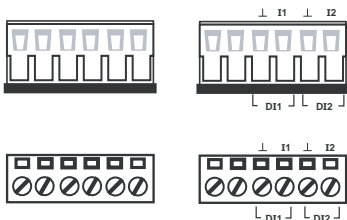

STEP 1: Insert the negative (ground)/positive DI wires into the \perp /I1 terminals, respectively.

STEP 2: To keep the DI wires from pulling loose, use a small flat-blade screwdriver to tighten the wire-clamp screws on the front of the terminal block connector.

STEP 3: Insert the plastic terminal block connector prongs into the terminal block receptor, which is located on the EDS-P506A-4PoE's top panel.

Turbo Ring DIP Switch Settings

EDS-P506A-4PoE switches are plug-and-play managed redundant Ethernet switches. The proprietary Turbo Ring protocol was developed by Moxa to provide better network reliability and faster recovery time. Moxa Turbo Ring's recovery time is less than 300 ms (**Turbo Ring**) or 20 ms (**Turbo Ring V2**)—compared to a 3- to 5-minute recovery time for commercial switches—decreasing the possible loss caused by network failures in an industrial setting.

There are 4 Hardware DIP Switches for Turbo Ring on the top panel of EDS-P506A-4PoE that can help setup the Turbo Ring easily within seconds. If you do not want to use a hardware DIP switch to setup the Turbo Ring, you can use a web browser, telnet, or console to disable this function.

NOTE Refer to the *Turbo Ring DIP Switch* section and *Using Communication Redundancy* section in the User's Manual for detailed information about the settings and usage of *Turbo Ring* and *Turbo Ring V2*.

EDS-P506A-4PoE Series DIP Switches

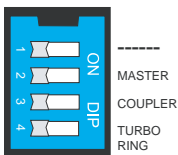

The default setting for each DIP Switch is OFF. The following table explains the effect of setting the DIP Switch to the ON position.

“Turbo Ring” DIP Switch Settings

DIP 1	DIP 2	DIP 3	DIP 4
Reserved for future use.	<u>ON</u> : Enables this EDS as the Ring Master.	<u>ON</u> : Enables the default “Ring Coupling” ports.	<u>ON</u> : Activates DIP switches 1, 2, 3 to configure “Turbo Ring” settings.
	<u>OFF</u> : This EDS will not be the Ring Master.	<u>OFF</u> : Do not use this EDS as the ring coupler.	<u>OFF</u> : DIP switches 1, 2, 3 will be disabled.

“Turbo Ring V2” DIP Switch Settings

DIP 1	DIP 2	DIP 3	DIP 4
<u>ON</u> : Enables the default “Ring Coupling (backup)” port.	<u>ON</u> : Enables this EDS as the Ring Master.	<u>ON</u> : Enables the default “Ring Coupling” port.	<u>ON</u> : Activates DIP switches 1, 2, 3 to configure “Turbo Ring V2” settings.
<u>OFF</u> : Enables the default “Ring Coupling (primary)” port.	<u>OFF</u> : This EDS will not be the Ring Master.	<u>OFF</u> : Do not use this EDS as a ring coupler.	<u>OFF</u> : DIP switches 1, 2, 3 will be disabled.

NOTE You must enable the Turbo Ring function first before using the DIP switch to activate the Master and Coupler functions.

NOTE If you do not enable any of the EDS-P506A-4PoE switches to be the Ring Master, the Turbo Ring protocol will automatically choose the EDS-P506A-4PoE with the smallest MAC address range to be the Ring Master. If you accidentally enable more than one EDS-P506A-4PoE to be the Ring Master, these EDS-P506A-4PoE switches will auto-negotiate to determine which one will be the Ring Master.

LED Indicators

The front panel of the Moxa EDS-P506A-4PoE contains several LED indicators. The function of each LED is described in the following table:

LED	Color	State	Description
PWR1	AMBER	On	Power is being supplied to power input P1.
		Off	Power is not being supplied to power input P1.
PWR2	AMBER	On	Power is being supplied to power input P2.
		Off	Power is not being supplied to power input P2.
FAULT	RED	On	When a user-configured event is triggered.
		Off	When a user-configured event is not triggered.
MSTR/HEAD	GREEN	On	When the EDS-P506A-4PoE is set as the Master of the Turbo Ring, or as the Head of the Turbo Chain.
		Blinking	The EDS-P506A-4PoE has become the Ring Master of the Turbo Ring, or the Head of the Turbo Chain, after the Turbo Ring or the Turbo Chain is down.
		Off	When the EDS-P506A-4PoE is not the Master of this Turbo Ring or is set as the Member of the Turbo Chain.
CPLR/TAIL	GREEN	On	When the EDS-P506A-4PoE coupling function is enabled to form a back-up path, or when it's set as the Tail of the Turbo Chain.
		Blinking	When the Turbo Chain is down.
		Off	When the EDS-P506A-4PoE disables the coupling function.
10M (TP)	GREEN	On	TP port's 10 Mbps link is active.
		Blinking	Data is being transmitted at 10 Mbps.
		Off	TP port's 10 Mbps link is inactive.
100M (TP)	GREEN	On	TP port's 100 Mbps link is active.
		Blinking	Data is being transmitted at 100 Mbps.
		Off	TP port's 100 Mbps link is inactive.
100M (FX)	GREEN	On	FX port's 100 Mbps link is active.
		Blinking	Data is being transmitted at 100 Mbps.
		Off	FX port's 100 Mbps link is inactive.
PoE+	AMBER	On	Power is being supplied to Powered Device (PD)
		Blinking	PoE port is in Power-Fail status
		Off	Power is not being supplied to Powered Device (PD)

Specifications of the EDS-P506A-4PoE Series

Auto MDI/MDI-X Connection

The Auto MDI/MDI-X function allows users to connect the EDS-P506A-4PoE's 10/100BaseTX ports to any kind of Ethernet device, without needing to pay attention to the type of Ethernet cable being used for the connection. This means that you can use either a *straight-through* cable or *cross-over* cable to connect the EDS-P506A-4PoE to Ethernet devices.

Fiber Ports

The Moxa EDS-P506A-4PoE's fiber ports operate at a fixed 100 Mbps speed and full-duplex mode to provide excellent performance. The fiber ports are factory-built as either multi-mode or single-mode SC/ST connectors. Therefore, you should use fiber cables that have SC/ST connectors at both ends. When plugging the connector into the port, make sure the slider guide is positioned to the right side such that it fits snugly into the port.

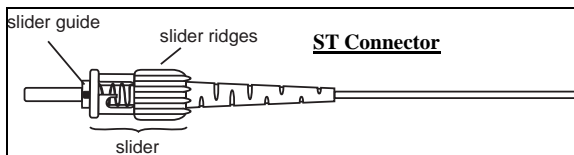
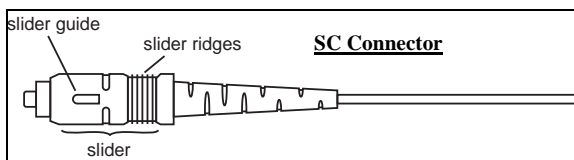

The 100 Mbps fiber ports are switched ports and perform as a domain to provide a high bandwidth backbone connection that supports long fiber cable distances (up to 5 km for multi-mode, and 40 km for single-mode) for installation flexibility.

Specifications

Technology	
Standards	IEEE802.3, 802.3u, 802.3x, 802.1D, 802.1w, 802.1Q, 802.1p, 802.1X, 802.3ad, 802.3af/at
Protocols	IGMPv1/v2, GVRP, SNMPv1/v2c/v3, DHCP Server/Client, BootP, TFTP, SNTP, SMTP, RARP, GMRP, LACP, RMON, HTTP, HTTPS, Telnet, Syslog, DHCP Option 66/67/82, SSH, SNMP Inform, Modbus/TCP, LLDP, IEEE 1588 PTP, IPv6
MIB	MIB-II, Ethernet-Like MIB, P-BRIDGE MIB, Q-BRIDGE MIB, Bridge MIB, RSTP MIB, RMON MIB Group 1,2,3,9
Processing Type	Store and Forward
Flow Control	IEEE802.3x flow control, back pressure flow control

Interface		
RJ45 Ports	10/100BaseT(X) auto negotiation speed, F/H duplex mode, and auto MDI/MDI-X connection	
Fiber Ports	100BaseFX ports (SC/ST connector)	
Console	RS-232 (RJ45)	
LED Indicators	PWR1, PWR2, FAULT, 10/100M (TP port), 100M (fiber port), MSTR/HEAD and CPLR/TAIL, PoE	
Relay Contact	Two relay outputs with current carrying capacity of 1 A @ 24 VDC	
DIP Switches	Master, Coupler, Turbo Ring, Reserve	
Digital Input	Two inputs with the same ground, but electrically isolated from the electronics <ul style="list-style-type: none"> • For state “1”: +13 to +30 V • For state “0”: -30 to +3 V • Max. input current: 8 mA 	
Optical Fiber		
	Multi-mode	Single-mode
Wavelength	1300 nm	1310 nm
Max. Tx	-10 dBm	0 dBm
Min. Tx	-20 dBm	-5 dBm
Rx Sensitivity	-32 dBm	-34 dBm
Link Budget	12 dB	29 dB
Typical Distance	5 km ^a 4 km ^b	40 km ^c
Saturation	-6 dBm	-3 dBm
a. using [50/125 μm, 800 MHz*km] cable b. using [62.5/125 μm, 500 MHz*km] cable c. using 9/125 μm cable		
Power		
Input Voltage	24/48 DC	
Input Current	Max. 7.8 A @ 24 VDC (supports up to 4 ports at 30 watts per PoE port)	
Overload current Protection	Present	
Connection	2 removable 6-contact terminal blocks	
Reverse Polarity Protection	Present	
Physical Characteristics		
Casing	IP30 protection, metal case	
Dimensions	80 x 135 x 131.5 mm (3.15 x 5.31 x 5.18 in)	
Weight	1270 g	
Installation	DIN-Rail, Wall Mounting (optional kit)	

Environmental	
Operating Temperature	0 to 60°C (32 to 140°F), -40 to 75°C (-40 to 167°F) for -T models
Storage Temperature	-40 to 85°C (-40 to 185°F)
Ambient Relative Humidity	5 to 95% (non-condensing)
Regulatory Approvals	
Safety	UL 508 (Pending)
EMI	FCC Part 15, CISPR (EN55022) class A
EMS	EN61000-4-2 (ESD), Level 3 EN61000-4-3 (RS), Level 3 EN61000-4-4 (EFT), Level 3 EN61000-4-5 (Surge), Level 3 EN61000-4-6 (CS), Level 3 EN61000-4-8
Shock	IEC60068-2-27
Freefall	IEC60068-2-32
Vibration	IEC60068-2-6
WARRANTY	5 years

Technical Support Contact Information
www.moxa.com/support

Moxa Americas:
Toll-free: 1-888-669-2872
Tel: +1-714-528-6777
Fax: +1-714-528-6778

Moxa China (Shanghai office):
Toll-free: 800-820-5036
Tel: +86-21-5258-9955
Fax: +86-10-6872-3958

Moxa Europe:
Tel: +49-89-3 70 03 99-0
Fax: +49-89-3 70 03 99-99

Moxa Asia-Pacific:
Tel: +886-2-8919-1230
Fax: +886-2-8919-1231